



@ Sony



VAIO

Save up to \$300 on VAIO® PC Packages\*

sony style. Mall level across from Bloomingdales

© 2008 Sony Electronics Inc. All rights reserved.



**W**  
ATLANTA  
BUCKHEAD

WHERE WILL WONDER JUST TAKE YOU?

In the city's most exciting neighborhoods, come to meet the coming hotel — the W Atlanta Buckhead. A five-star hotel, landmark accommodations, upscale dining, luxury shopping and the finest nightlife. It's where modern luxury meets Southern charm.

W Atlanta Buckhead AUCTIONING now at LENOX SQUARE.  
To view plans at [www.watlantabuckhead.com](http://www.watlantabuckhead.com)

W Atlanta Buckhead is a project of W Hotels, a Division of Marriott International.

# BannerDrop®

*Put Ceiling Space To Work with the Push of a Button.  
Britten's Revolutionary BannerDrop® Hoists Banners Hassle-Free, Lift-Free.*



Montehiedra Mall (San Juan, PR)



King of Prussia Mall (Philadelphia, PA)



Castleton Square (Indianapolis, IN)

**Now this is easy:** Hit a remote-control button and old banners come down, new banners go up – way up... as high as 60 feet – staying smooth and level. Britten's patented BannerDrop® makes it happen.

It's so quick and cost-effective, you can easily display and change an endless succession of banners. Best of all, BannerDrop eliminates the expense, risks, labor and insurance associated with traditional lift rentals.

BannerDrop can handle large banners of any type, die-cut or framed, horizontal or vertical.

Have a special challenge? We'll rise to it, as always, and develop a custom solution that meets your needs.

## From Innovative to Indispensable – BannerDrop

- Turns empty space into revenue space
- Ideal for revenue-producing ads, sponsored messages, attention-getting announcements
- Quickly raises, lowers and replaces banners with pushbutton ease
- Delivers big savings on expensive lift rental, labor and insurance costs
- No insurance, safety risks, or mess of using lifts
- Accommodates a wide range of banners – you name it, BannerDrop hangs it
- Lifts up to 140 lbs.
- Reliable – already in use in hundreds of shopping malls, arenas, stadiums, universities, and airports
- Backed by Britten's legendary customer support

1.800.426.9496

[www.BrittenBanners.com](http://www.BrittenBanners.com)

*Innovative? Cost-Effective?  
Just What You'd Expect from Britten – and Just What You Need.*

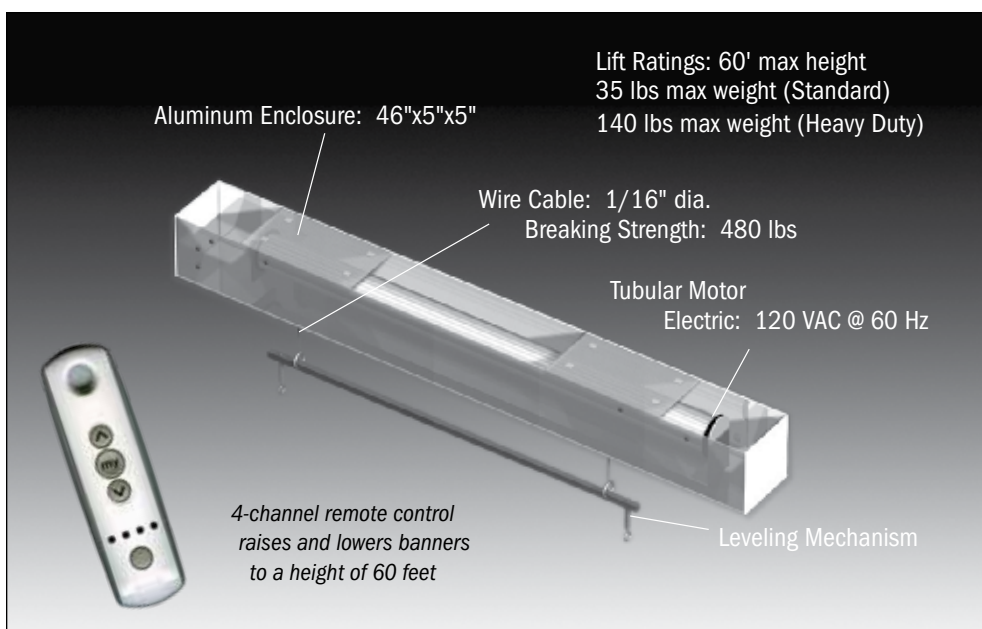

> To view fast, easy BannerDrop in action, go to [www.youtube.com](http://www.youtube.com) and search "bannerdrop"

Our exclusive BannerDrop design was inspired by customers' complaints and frustrations with lift rentals and empty, non-productive, non-profitable ceiling space. We responded, building features into BannerDrop that make it easy to bring a revenue-generating, image-enhancing banner program to your high spaces.

#### Keys to BannerDrop Performance

- **4-channel remote control.** Push a button to raise or lower displays. BannerDrop can raise your displays to a height of 60'.
- **UL-approved solid-state, tubular motor.** BannerDrop's reliable operations have been proven in many of the nation's busiest retail and event locations.
- **Strong, durable cables.** Made of stainless steel for years of trouble-free, maintenance-free service.
- **120 power or optional battery operation.** BannerDrop is energy-thrifty – and far more efficient than lifts.
- **Patented cable indexing mechanism.** Unique design eliminates wire tangling, keeps banners level at all heights.

- **Clean construction – paintable to match ceilings.** Banner is held clean and smooth by an anodized aluminum frame, suspended from a paintable aluminum casing. We also have a fabric solution.
- **Available in several versions.** BannerDrop Standard lifts up to 35 lbs., BannerDrop Heavy Duty up to 140 lbs. BannerDrop has also been custom-engineered for international use and many unique applications.
- **Warranty available.**

# BannerDrop<sup>®</sup>

*"We used to pay over \$1000 for every day we rented a lift at our mall. Now, thanks to BannerDrop we don't need lifts and we can easily adjust the height of our banners."*

*– Shopping mall development company, Laurel, MD*



McCarran International Airport (Las Vegas, NV)



South Station (Boston, MA)



Madison Square Garden (New York City, NY)

Like magic, Britten's BannerDrop lowers costs and raises revenues. Our customers report additional earning potential from banner ads of \$12,000 per month and over \$15,000 in lift-rental savings per year. Typically, BannerDrop saves customers an average \$1,800 every time an ad changes!

For customers used to relying on lifts to hang and replace banners, BannerDrop's ease-of-use and cost-savings make ceiling-mounted ads more profitable than ever before. For still others, BannerDrop makes this new source of revenue practical for the first time.

Explore what BannerDrop can mean to *your* operations and marketing. And get ready to boost your profits to new heights.

Ready to go? Want to learn more?  
Call us toll-free 24/7 at **1.800.426.9496** or visit [www.BrittenBanners.com](http://www.BrittenBanners.com)

**Britten**<sup>®</sup>  
Banner Partner to the World